



自动转换开关选型样本

Catalogue - Automatic Transfer Switch

2012

中国 上海

www.hielec.com



海纳百川有容乃大，亿万斯年生生不息

Be Inclusive and Initiative

企业简介

Company Profile

上海海亿电气成立于2008年，致力于低压电气产品的研发、制造、销售，向广大用户提供专业化、高品质的低压电气产品。

SHANGHAI HIELEC ELECTRICAL CO., LTD. was founded in 2008. We focus on developing, manufacturing, selling of low voltage electrical products as a specialized company and supply professional, high quality products to customers.

产品特点 Product Features

- A、采用双列复合式触头、横拉式机构、微电机预储能以及电子控制技术，基本实现零飞弧。由逻辑控制板来控制置于开关内的电机、变速箱来保证开关操作到正确的位置。
Double-row composite contact, horizontal pull-type mechanism, micro-motor with energy pre-store and electronic control technology have been used to extinguish arc. Through logic control PCB to control the motor and gear case to make the switch on right position.
- B、可靠的机械联锁和电气联锁。
Reliable mechanical interlock and electrical interlock.
- C、稳定的零位，紧急情况下可强制置零（同时切断两路电源）。
Stable “0” position. Reset to “0” position in case of emergency (break both of the two power supplies).
- D、具有明显通断位置显示、挂锁等功能，可靠实现电源与负载间的隔离。
Obvious ON/OFF indication and padlock to realize isolation between power supply and load.
- E、聚氯丁橡胶绝缘湿热型电机，装有安全装置，在超出110℃温度和过电流状态时跳闸，在故障消失后即自动投入工作。可逆减速齿轮采用直齿齿轮。
Polychloroprene rubber insulation damp-heat type motor equipped with safety device, which trips off automatically when there is over-temperature (above 110℃) and over-current. Put into service automatically when the fault is removed. A straight-tooth gear is adopted for the reversible reduction gear.
- F、外壳采用不饱和聚脂纤维制成，耐火、耐压、耐高温性极强。
The shell of switch body is made of unsaturated polyester fibre, which is with strong characteristic of fireproof, high voltage withstand, high temperature resistant.

符合标准 Conformity to Standards

- IEC60947-1/GB14048.1-2008 《低压开关设备和控制设备总则》
- IEC60947-3/GB14048.3 《低压开关设备和控制设备低压开关，隔离器，隔离开关及熔断器组合器》
- IEC60947-6-1/GB14048.11 《自动转换开关电器》

型号与示意 Type and Meaning

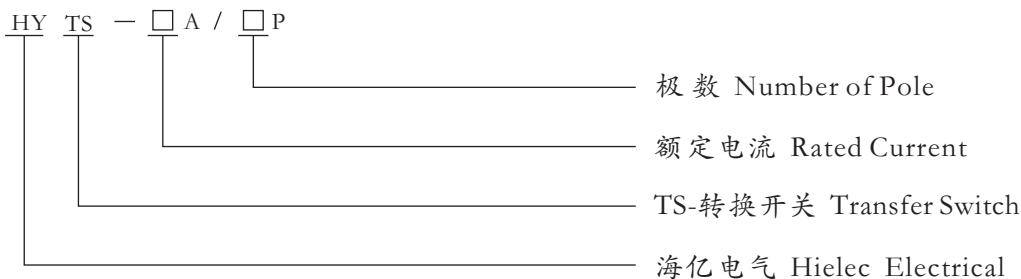

技术参数 Characteristics

约定发热电流Ith(40°C) Rated thermal current Ith(40°C)		20A	40A	63A	80A	100A	125A	160A	250A	400A	
额定绝缘电压Ui(V) Rated insulation voltage Ui(V)		750V					1000V				
额定冲击耐受电压Uimp(KV) Rated impulse withstand voltage Uimp(KV)		8KV					12KV				
额定工作电流Ie(A) (根据GB14048/IEC60947) Rated operational currents Ie(A) according to GB14048/IEC60947											
额定电压 Rated voltage	负载类型 Load duty category										
440VAC	AC-31A/B	20	40	63	80	100	125	160	250	400	
	AC-33A/B	20	40	63	80	100	125	160	250	400	
	AC-35A/B	20	40	63	80	100	125	160	250	400	
220VDC	DC-31A/B	20	40	63	80	100	125	160	250	400	
	DC-33A/B	20	40	63	80	100	125	160	250	400	
440VDC	DC-31A/B	20	40	63	80	100	125	160	250	400	
	DC-33A/B	20	40	63	80	100	125	160	250	400	
额定接通能力 Rated making capacity		10Ie									
额定分断能力 Rated breaking capacity		8Ie									
额定限制短路电流 Prospective short-circuit current		100KA							70KA		
额定短时耐受电流Icw(1s) Rated short-time withstand current Icw(1s)		9KA					13KA		26KA		
转换时间 I - II 或 II - I Switching time I - II or II - I		0.45S					0.6S				
辅助电源电压 Aux power supply voltage		220VAC (其它电压规格请联系海亿) (Please contact Hielec for other voltage)									
电机能耗(W) Energy consumption of motor(W)											
启动Startup		300					325		355		
正常Normal		55					62		74		
重量 Weight(kg)		4.5					7.5		9		16.5

约定发热电流Ith(40℃) Rated thermal current Ith(40℃)	630A	800A	1000A	1250A	1600A	2000A	2500A	3200A	
额定绝缘电压Ui(V) Rated insulation voltage Ui(V)	1000V								
额定冲击耐受电压Uimp(KV) Rated impulse withstand voltage Uimp(KV)	12KV								
额定工作电流Ie(A) (根据GB14048/IEC60947) Rated operational currents Ie(A) according to GB14048/IEC60947									
额定电压 Rated voltage	负载类型 Load duty category								
440VAC	AC-31A/B	630	800	1000	1250	1600	2000	2500	3200
	AC-33A/B	630	800	1000	1250	1600	2000	2500	3200
	AC-35A/B	630	800	1000	1250	1600	2000	2500	3200
220VDC	DC-31A/B	630	800	1000	1250	1600			
	DC-33A/B	630	800	1000	1250	1600			
440VDC	DC-31A/B	630	800	1000	1250	1600			
	DC-33A/B	500	800	1000	1000	1600			
额定接通能力 Rated making capacity	10Ie								
额定分断能力 Rated breaking capacity	8Ie								
额定限制短路电流 Prospective short-circuit current	70KA	100KA		120KA		80KA			
额定短时耐受电流Icw(1s) Rated short-time withstand current Icw(1s)	26KA	50KA		55KA					
转换时间 I - II 或 II - I Switching time I - II or II - I	0.6S	1.2S				2.4S			
辅助电源电压 Aux power supply voltage	220VAC (其它电压规格请联系海亿) (Please contact Hielec for other voltage)								
电机能耗(W) Energy consumption of motor(W)									
启动Startup	355	400		440		600			
正常Normal	74	90		98		120			
重量 Weight(kg)	17	32	36	40	49	95	98	135	

尺寸 Dimensions

20A—100A

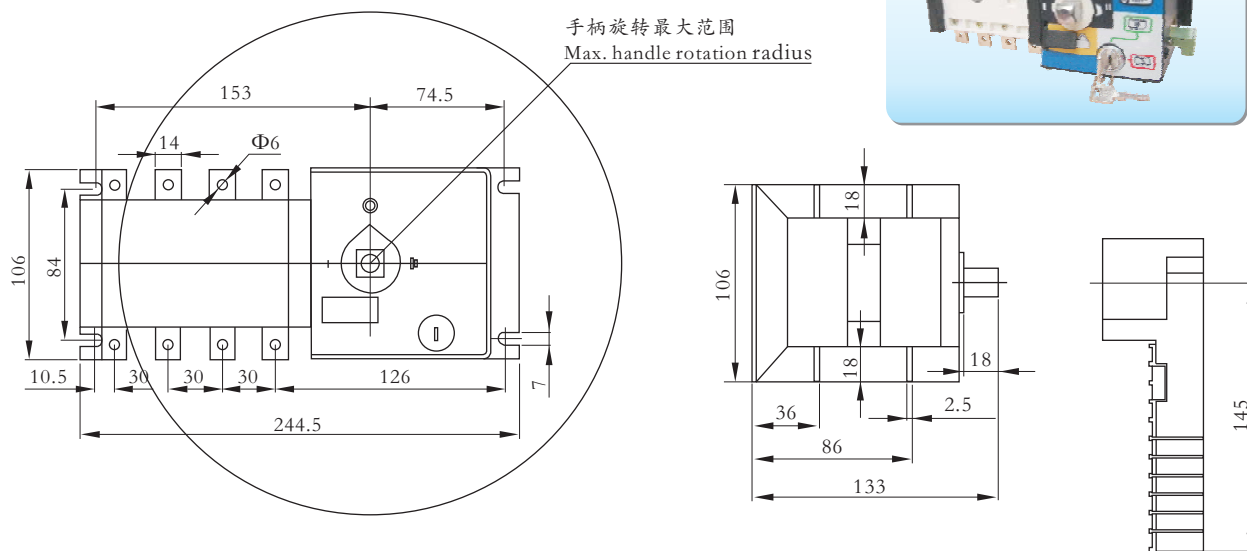

125A—3200A

125A-1600A



2000A-3200A



电气控制的接线端子
Electrical control wiring terminal

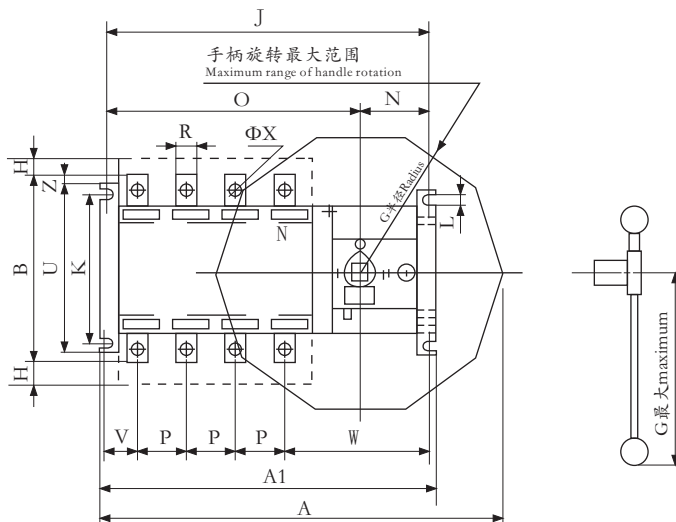
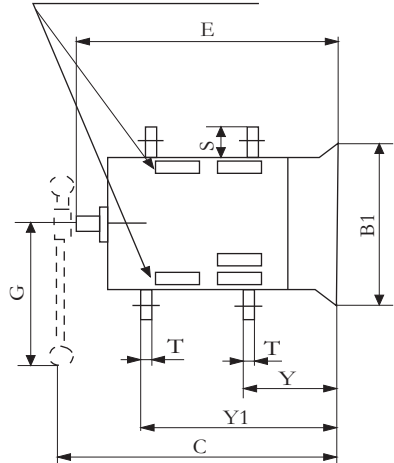

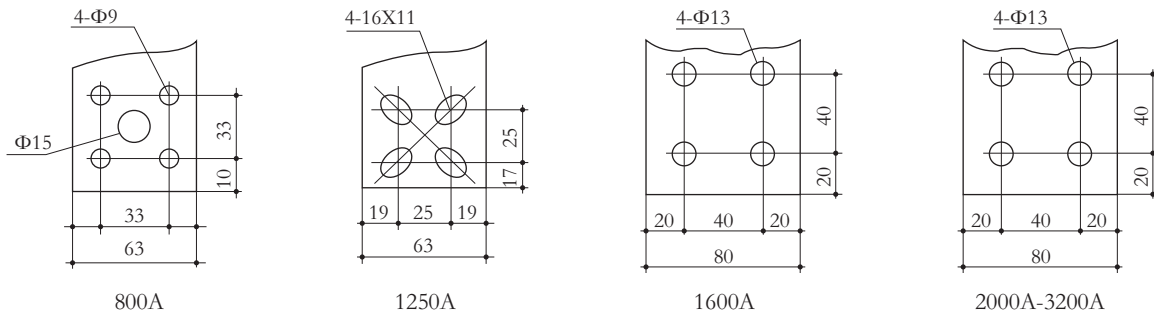

尺寸表 Dimensions Sheet

规格 Specification	总尺寸 Overall dimensions						开关安装 Setting of switch						接线端子 Wiring terminal											
	A	A1	B	B1	C	E	G	H	J	K	L	N	O	P	R	S	U	T	V	W	X	Y	Y1	Z
20-100A	320	244.5	106	106	170	137	145		227.5	84	7	74.5	153	30	14	18	106	2.5	10.5	126	6	36	86	
125A	435	303	141.5	135	251	195	220	30	280	95	7	86	194	36	20	25	130	3.5	20	152	9	58	136.5	8
160A	435	303	141.5	135	251	195	220	30	280	95	7	86	194	36	20	25	130	3.5	20	152	9	58	136.5	8
250A	453	359	170	135	251	195	220	30	339	95	7	86	253	50	25	30	130	3.5	25	162	11	60.5	136.5	15
400A	525	433	270	228	319	262	220	25	413	180	9	89	324	65	40	50	201	5	40	108.5	13	82.5	192.5	20
630A	525	433	270	228	319	262	220	25	413	180	9	89	324	65	40	50	201	6	40	108.5	13	82.5	195.5	20
800A	1007	633	350	250	370	321	470	65	609	220	11	85	524	120	63	65	250	7	60.5	188.5		107	249	
1000A	1007	633	350	250	370	321	470	65	609	220	11	85	524	120	63	65	250	7	60.5	188.5		107	249	
1250A	1007	633	350	250	370	321	470	65	609	220	11	85	524	120	63	65	250	7	60.5	188.5		107	249	
1600A	1007	633	407	250	370	321	470	65	609	220	11	85	524	120	80	80	250	10	60.5	188.5		111	253	
2000A	1007	633	470		562	500	470	53	467	220 350	11	85	524	120	80	80	250 400	15	60.5	188.5		147	378	
2500A	1007	633	470		562	500	470	28	467	220 350	11	85	524	120	120	100	250 400	15	60.5	188.5		152	388	
3200A	1007	633	470		562	500	470	28	467	220 350	11	85	524	120	120		250 400	15	60.5	188.5		152	388	

注: 2000-3200A 开关中间部位增加了一付加强型安装脚, 其尺寸(K、U)比两端的大。
 Note: For 2000-3200A, an enhanced installation bar has been added in the middle, the size (K,U) is more bigger.

安装方向 Mounting Orientation

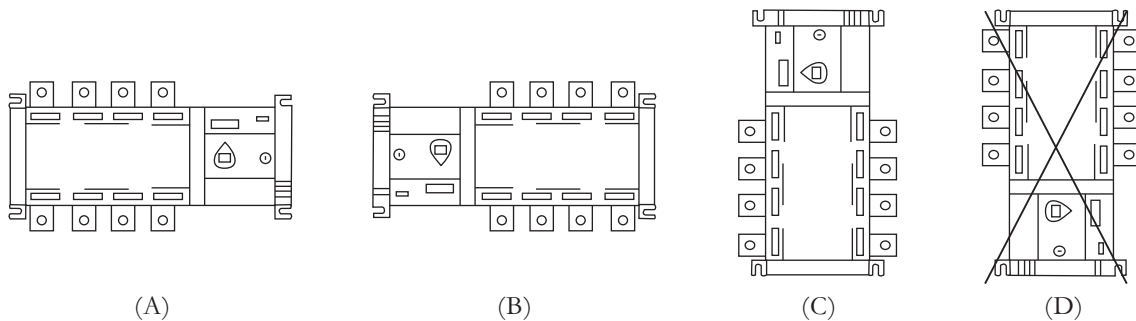

接线方式Wiring

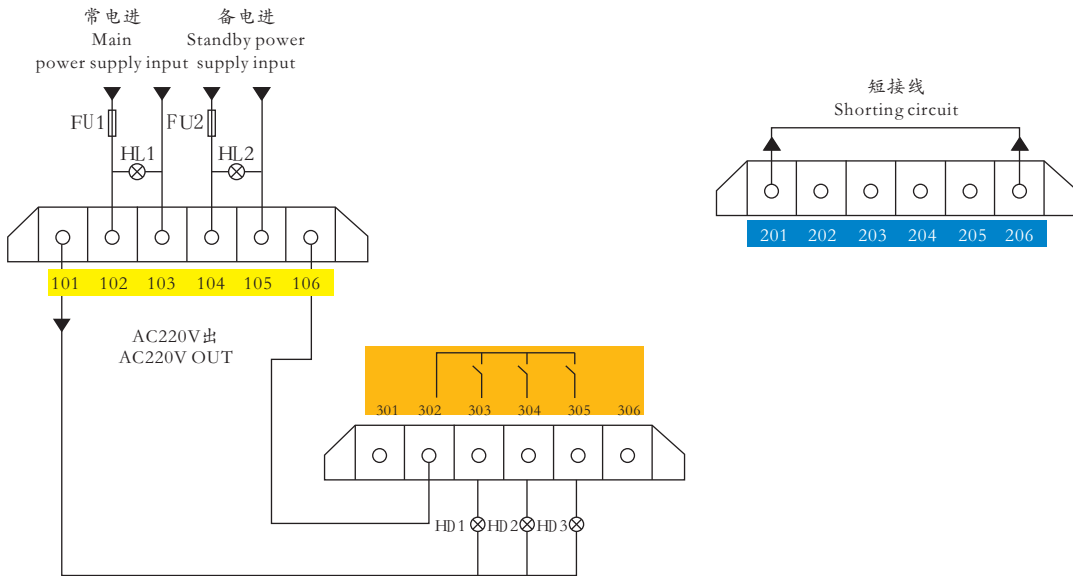

改变2号端子外部接线方式可具有以下几 功能：

Changing external wiring mode of terminal 2 to get following functions

- 1) 强置零：全自动+强置“0”（双路电源切断）
Compulsory reset to zero:
Fully automatic + compulsory reset to “0” (double power supplies are cut off).

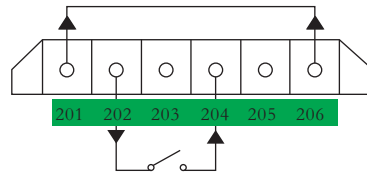

强置“0”（自锁开关）
Compulsory reset to “0” (switch self-locked)

- 2) 远控：自动/手动(过控)+强置“0”
Remote control: Auto/manual (over control) + compulsory reset to “0” .

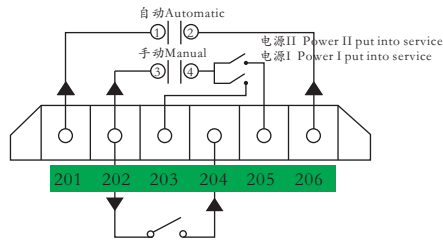

强置“0”（自锁开关）
Compulsory reset to “0” (switch self-locked)

4号/5号端子Terminal 4/5

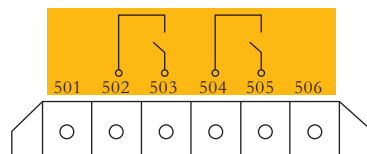
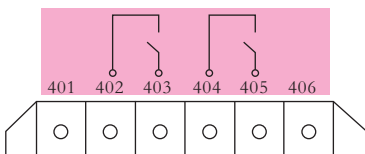

端子定义Terminal Description

端子组别 Terminal Group	功能 Function	端子号 Terminal No.	描述 Description
1号端子 Group1	辅助电源 Aux.Power Supply	101	辅助电源输出 Aux. Power Output
		106	
		102	辅助电源 I 输入 Aux.Power Input(I)
		103	
		104	辅助电源 II 输入 Aux.Power Input(II)
		105	
2号端子 Group2	控制信号 Control Signal	201	短接可实现全自动切换 Auto transfer with short circuit
		206	
		202	控制信号公共端 COM for control signal
		203	切换到位置 I 的控制信号输入 Control signal (transfer to I)
		204	切换到位置 0 的控制信号输入 Control signal (transfer to 0)
		205	切换到位置 II 的控制信号输入 Control signal (transfer to II)
3号端子 Group3	辅助触点 Aux.Contact	301	内部已经短接 Short circuit inside
		306	
		302	开关位置指示信号公共端 COM for Aux. contact
		303	开关位置指示信号 (I 位置) Aux.contact(I) N/O
		304	开关位置指示信号 (0 位置) Aux.contact(0) N/O
		305	开关位置指示信号 (II 位置) Aux.contact(II) N/O
4号端子 Group4	合闸状态 State of switch	401	内部已经短接 Short circuit inside
		406	
		402	开关 I 路合闸状态指示 (常开) ON/OFF indication of switch I (N/O)
		403	
		404	开关 II 路信号合闸状态指示(常开) ON/OFF indication of switch II (N/O)
		405	
5号端子 Group5	手/自动模式及开 关挂锁状态指示 Mode Selection & Padlocking	501	内部已经短接 Short circuit inside
		506	
		502	开关工作模式指示: 钥匙开关置于“手动”时断开, 置于“自动”时闭合 Mode:open when select “manuel” mode; close when select “Auto” mode
		503	
		504	开关挂锁状态指示: 开关未挂锁时闭合, 挂锁后断开 Padlocking: “close”-without padlocking, “open”-with padlocking.
		505	

注: 400A以下无4号及5号端子
Note:There is no terminal 4&5 on the switches <400A

概述 Brief Description

HYC608控制器集测量、显示、控制、三遥功能于一体，适用于市电—发电、市电—市电、发电—发电等双电源系统的自动转换控制，具有以下特点：

HYC608 controller has the functions of measurement, display, control, 3-remotes. It could be used for the ATS control between Network-Generator, Network-Network, Generator - Generator, and has following characteristics:

微机控制，全数字化技术；

Digital technology based on micro-processor

通过面板按键设定控制器运行方式；

Set working mode of the controller through key-press on the panel

通过LED直观显示ATS的运行状态、控制器运行模式；

Use LED to display the situation of ATS and the working mode of the controller

通过面板LED数码管显示和按键，设定运行参数；

Set the parameters trough the LED display and key-press

通过LED显示测量数据，包括电压、频率；

Display the measuring data include voltage and frequency through LED display

通过RS485/RS232通讯口实现三遥功能或与PC通讯，并可读出和设置控制器的运行参数；

3-remote functions or connected with PC through RS485/232 communication port.

控制器采用DIN96标准外壳，所有连线都通过针式带锁的端子连接，令控制器的连线、移动、维修、更换容易和方便。

Standard dimensions according to DIN96. All wiring is through pin-wiring terminal with lock function.

HYC608

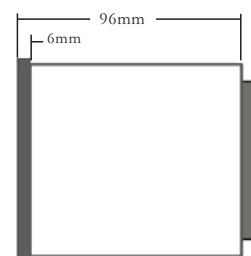
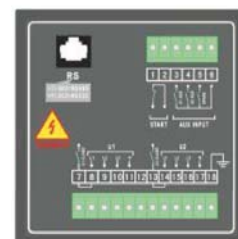
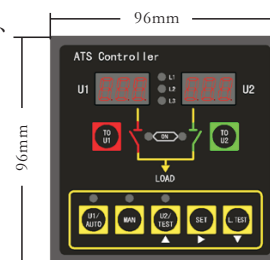

技术参数表Parameter Sheet

测量和显示数据 Data of Measurement and Display

U1(常用电源侧)电压 Voltage of U1 (Main): L1-N,L2-N,L3-N	U2(备用电源侧)电压 Voltage of U2 (Standby): L1-N,L2-N,L3-N
U1(常用电源侧)频率 Frequency of U1 (Main): Hz	U2(备用电源侧)频率 Frequency of U2 (Standby): Hz

开关量输入 Digital Input

常用电源侧开关合闸信号 Switch Close Signal of Main	备用电源侧开关合闸信号 Switch Close Signal of Standby
备用 Backup	

继电器输出 Relay Output

U1(常用电源侧)开关合闸控制输出 Control Signal-Transfer to U1	U2(备用电源侧)开关合闸控制输出 Control Signal-Transfer to U2
发电机组遥开信号 Generator Startup Signal	

可设置的运行参数 Settable Parameters

通讯地址 Communication Address: 1-255	发电机组冷却延时时间 Time Delay of Generator Cool-down: 0-999s
U1电源低电压故障值 U1 Under-voltage: 145-220VAC	U2电源低电压故障值 U2 Under-voltage: 145-220VAC
U1电源高电压故障值 U1 Over-voltage: 220-265VAC	U2电源高电压故障值 U2 Over-voltage: 220-265VAC
U1电源低频率故障值 U1 Under-frequency: 45-50Hz	U2电源低频率故障值 U2 Under-frequency: 45-50Hz
U1电源高频率故障值 U1 Over-frequency: 50-70Hz	U2电源高频率故障值 U2 Over-frequency: 50-70Hz
U1电源故障延时确认时间 Time Delay of U1 Failure: 0-250s	U2电源故障延时确认时间 Time Delay of U2 Failure: 0-250s
U1电源供电延时时间 Time Delay of U1 Available: 0-250s	U2电源供电延时时间 Time Delay of U2 Available: 0-250s

工作电源 Aux. Power Supply

工作电压 Voltage of Aux. Power: 85-265VAC	功耗 Power Consumption : <3W
---------------------------------------	----------------------------

概述 Brief Description

HYC610控制器集测量、显示、控制、三遥功能于一体，其三子型号（NN、NG、GG）分别用于市电-市电、市电-发电、发电-发电的双电源自动转换系统控制，具有以下特点：

HYC610 controller has the functions of measurement, display, control, 3-remotes. The 3 sub-types (NN, NG, GG) could be respectively used for the ATS control between Network-Network, Network-Generator, Generator-Generator. It has following characteristics:

微机控制，全数字化技术；

Digital technology based on micro-processor

通过面板按键设定控制器运行方式；

Set working mode through key-press on the panel

通过LED直观显示ATS的运行状态、控制器运行模式；

Used LED to display the situation of ATS and the working mode of the controller

通过面板LED数码管显示和按键，设定运行参数；

Set the parameters through the LED display and key-press

通过LED显示测量数据，包括电压、频率；

Display the measuring data include voltage and frequency through LED display

通过RS485/RS232通讯口实现三遥功能或与PC通讯，并可读出和设置控制器的运行参数；

3-remote functions or connected with PC through RS485/232 communication port

控制器采用DIN96标准外壳，所有连线都通过针式带锁的端子连接，令控制器的连线、移动、维修、更换容易和方便。

Standard dimensions according to DIN96. All wiring is through pin-wiring terminal with lock function.

HYC610

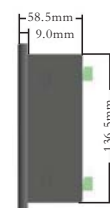
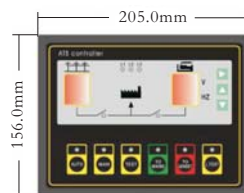

NN



NG



GG

技术参数表Parameter Sheet

HYC610-NN

测量和显示数据 Data of Measurement and Display

市电1侧电压Voltage of Network 1 : L1-N, L2-N, L3-N	市电2侧电压Voltage of Network 2 : L1-N, L2-N, L3-N
市电1侧频率Frequency of Network 1 : Hz	市电2侧频率Frequency of Network 2 : Hz

开关量输入 Digital Input

市电1侧开关合闸信号Switch Close Signal of Network 1 Side	市电2侧开关合闸信号Switch Close Signal of Network 2 Side
---	---

继电器输出Relay Output

市电1侧开关合闸控制输出Control Signal-Transfer to Network 1	市电2侧开关合闸控制输出Control Signal-Transfer to Network 2
--	--

可设置的运行参数 Settable Parameters

通讯地址Communication Address: 1-255	
市电1低电压故障值Under-voltage of Network1: 45-220VAC	市电2低电压故障值Under-voltage of Network2: 45-220VAC
市电1高电压故障值Over-voltage of Network1: 110-265VAC	市电2高电压故障值Over-voltage of Network2: 110-265VAC
市电1低频率故障值Under-frequency of Network1: 45-50Hz	市电2低频率故障值Under-frequency of Network2: 45-50Hz
市电1高频率故障值Over-frequency of Network: 50-70Hz	市电2高频率故障值Over-frequency of Network2: 50-70Hz
市电1故障延时确认时间Network1 Failure Time Delay: 0-250s	市电2故障延时确认时间Network2 Failure Time Delay: 0-250s
市电1供电延时时间: Network1 Available Time Delay: 0-250s	市电2供电延时时间Network2 Available Time Delay: 0-250s

工作电源Aux. Power Supply

工作电压Voltage of Aux. Power: 85-265VAC	功耗Power Consumption : <3W
--------------------------------------	---------------------------

HYC610-NG

测量和显示数据 Data of Measurement and Display			
市电侧电压Voltage of Network :	L1-N, L2-N, L3-N	发电侧电压Voltage of Generator :	L1-N, L2-N, L3-N
市电侧频率Frequency of Network :	Hz	发电侧频率Frequency of Generator :	Hz
开关量输入 Digital Input			
市电侧开关合闸信号Switch Close Signal of Network Side		发电侧开关合闸信号Switch Close Signal of Generator Side	
继电器输出Relay Output			
市电侧开关合闸控制输出Control Signal-Transfer to Network		发电侧开关合闸控制输出Control Signal-Transfer to Generator	
发电机组启动信号Generator Starting Signal			
可设置的运行参数 Settable Parameters			
通讯地址Communication Address:	1-255	发电机组冷却延时时间Time Delay of Generator Cool-down:	0-999s
市电低电压故障值Under-voltage of Network:	45-220VAC	发电低电压故障值Under-voltage of Generator:	45-220VAC
市电高电压故障值Over-voltage of Network:	110-265VAC	发电高电压故障值Over-voltage of Generator:	110-265VAC
市电低频率故障值Under-frequency of Network:	45-50Hz	发电低频率故障值Under-frequency of Generator:	45-50Hz
市电高频率故障值Over-frequency of Network:	50-70Hz	发电高频率故障值Over-voltage of Generator:	50-70Hz
市电故障延时确认时间Main Failure Time Delay:	0-250s	发电故障延时确认时间Generator Failure Time Delay:	0-250s
市电供电延时时间Main Available Time Delay:	0-250s	发电供电延时时间Generator Available Time Delay:	0-250s
工作电源Aux. Power Supply			
工作电压Voltage of Aux. Power:	85-265VAC/8-35VDC	功耗Power Consumption :	<3W

HYC610-GG

测量和显示数据 Data of Measurement and Display			
发电1侧电压Voltage of Generator 1 :	L1-N, L2-N, L3-N	发电2侧电压Voltage of Generator 2 :	L1-N, L2-N, L3-N
发电1侧频率Frequency of Generator 1 :	Hz	发电2侧频率Frequency of Generator 2 :	Hz
开关量输入 Digital Input			
发电1侧开关合闸信号Switch Close Signal of Generator 1 Side		发电2侧开关合闸信号Switch Close Signal of Generator 2 Side	
发电1机组故障Generator1 Failure		发电2机组故障Generator 2 Failure	
发电机组遥开信号Re-mote Generator Starting Signal			
继电器输出Relay Output			
发电1侧开关合闸控制输出Control Signal-Transfer to Generator 1		发电2侧开关合闸控制输出Control Signal-Transfer to Generator 2	
发电1机组启动信号Generator 1 Starting Signal		发电2机组启动信号Generator 2 Starting Signal	
可设置的运行参数 Settable Parameters			
通讯地址Communication Address:	1-255	自动轮换时间Auto-shift Time Delay:	0-18h
发电1低电压故障值Under-voltage of Generator1:	45-220VAC	发电2低电压故障值Under-voltage of Generator2:	45-220VAC
发电1高电压故障值Over-voltage of Generator1:	110-265VAC	发电2高电压故障值Over-voltage of Generator2:	110-265VAC
发电1低频率故障值Under-frequency of Generator1:	45-50Hz	发电2低频率故障值Under-frequency of Generator2:	45-50Hz
发电1高频率故障值Over-voltage of Generator1:	50-70Hz	发电2高频率故障值Over-voltage of Generator2:	50-70Hz
发电1故障延时确认时间Generator1 Failure Time Delay:	0-250s	发电2故障延时确认时间Generator1 Failure Time Delay:	0-250s
发电1供电延时时间Generator1 Available Time Delay:	0-250s	发电2供电延时时间Generator1 Available Time Delay:	0-250s
发电1冷却延时时间Generator1 Cool Down Time Delay:	0-999s	发电2冷却延时时间Generator2 Cool Down Time Delay:	0-999s
工作电源Aux. Power Supply			
工作电压Voltage of Aux. Power:	8-35VDC	功耗Power Consumption :	<3W

概述 Brief Description

HYC618控制器集测量、显示、控制、三遥等功能于一体，适用具有0位的三工作状态的转换开关的自动控制使用，具有以下特点：

HYC618 controller has the functions of measurement, display, control, 3-remotes, and could be used for ATS control which needs position "0". It has following characteristics :

微机控制、全数字化技术；

Digital technology based on micro-processor

通过面板按键设定控制器的运行方式；

Set working mode through key-press on the panel

通过LED直观指示ATS的运行状态、控制器运行模式；

Used LED to display the situation of ATS and the working mode of the controller

通过面板LCD液晶显示和按键，设定运行参数；

Set the parameters through the LCD display and keyboard

通过LCD显示测量数据，包括电压、频率等电参数；

Display the measuring data include voltage and frequency through LED display

通过RS485通讯口实现三遥功能或与PC连接，可读写、修改所有设定值和参数；

3-remote functions or connected with PC through RS485/232 communication port

控制器的所有连接线都通过针式带锁的端子连接，便于控制器的连线、移动、维修、更换。

All wiring is through pin-wiring terminal with lock function.

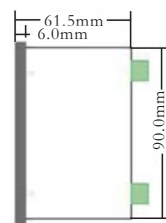
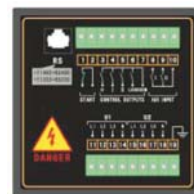
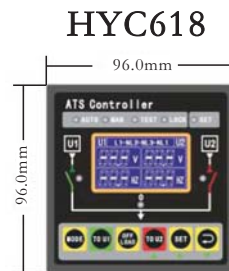

技术参数表Parameter Sheet

测量和显示数据 Data of Measurement and Display

U1常用电源相电压Voltage Ph-N of U1(Main):L1-N,L2-N,L3-N	U2备用电源相电压Voltage Ph-N of U2(Standby):L1-N,L2-N,L3-N
U1常用电源线电压Voltage Ph-Ph of U1(Main):L1-L2,L2-L3,L3-L1	U2备用电源线电压Voltage Ph-Ph of U2(Standby):L1-L2,L2-L3,L3-L1
U1常用电源频率Frequency of U1(Main):	Hz
U2备用电源频率Frequency of U2(Standby):	Hz

开关量输入 Digital Input

转换开关辅助触点输入ATS Aux. Contact Input: *2

继电器输出Relay Output

转换到位置U1 Control Signal-Transfer to Position "U1"	转换到位置U2 Control Signal-Transfer to Position "U2"
转换到位置0 Control Signal-Transfer to Position "0"	
控制逻辑设定 Control Logic Setting	发电机组遥开信号 Generator re-mote Startup Signal

可设置的运行参数 Settable Parameters

通讯地址Communication Address:	1-255	转换系统类型Type of Power System:	1=NG; 2=NN
U1电源低电压故障值Under-voltage of U1:	45-220VAC	U2电源低电压故障值U2 Under-voltage:	45-220VAC
U1电源高电压故障值Over-voltage of U1:	110-265VAC	U2电源高电压故障值U2 Over-voltage:	110-265VAC
U1电源低频率故障值Under-frequency of U1:	45-60Hz	U2电源低频率故障值U2 Under-frequency:	45-60Hz
U1电源高频率故障值U1 Over-frequency:	50-70Hz	U2电源高频率故障值U2 Over-frequency:	50-70Hz
U1电源故障延时确认时间U1 Failure Time Delay:	0-250s	U2电源故障延时确认时间U2 Failure Time Delay:	0-250s
U1电源供电延时时间U1 Available Time Delay:	0-250s	U2电源供电延时时间 U2 Available Time Delay:	0-250s
U1电源供电失败延时时间U1 Fail Supply Time Delay:	0-999s	U2电源供电失败延时时间U2 Fail Supply Time Delay:	0-999s

工作电源Aux. Power Supply

工作电压Voltage of Aux. Power:	85-265VAC	功耗Power Consumption :	<4W
----------------------------	-----------	-----------------------	-----

其它参数Other Parameters

- A. 测量交流电压输入 Measurement Voltage Input : 75-300VAC (ph-N) .
- B. 电压测量精度 Precision of Voltage Measurement : 0.5.
- C. 使用环境温度 Working Temperature : -20~50°C.
- D. 存储环境温度 Store Temperature : -30~80°C.

其它型号Other Types

- HYC601 经济型，模拟控制 Economic type, analog control.
- HYC620 基于HYC618，直流供电，可测量功率、功率因数 Based on HYC 618, DC Aux. power supply, can measuring power and power factor.
- HYC630 用于同步转换控制 Used for synchronous transfer control.
- HYC650 用于3路电源系统的转换控制 Used for 3 power supplies system transfer control.

具体参数规格请联系海亿 Please contact HIELEC for details.

转换开关在不同电源系统中的应用
The Application of ATS in Different Power Supply Systems

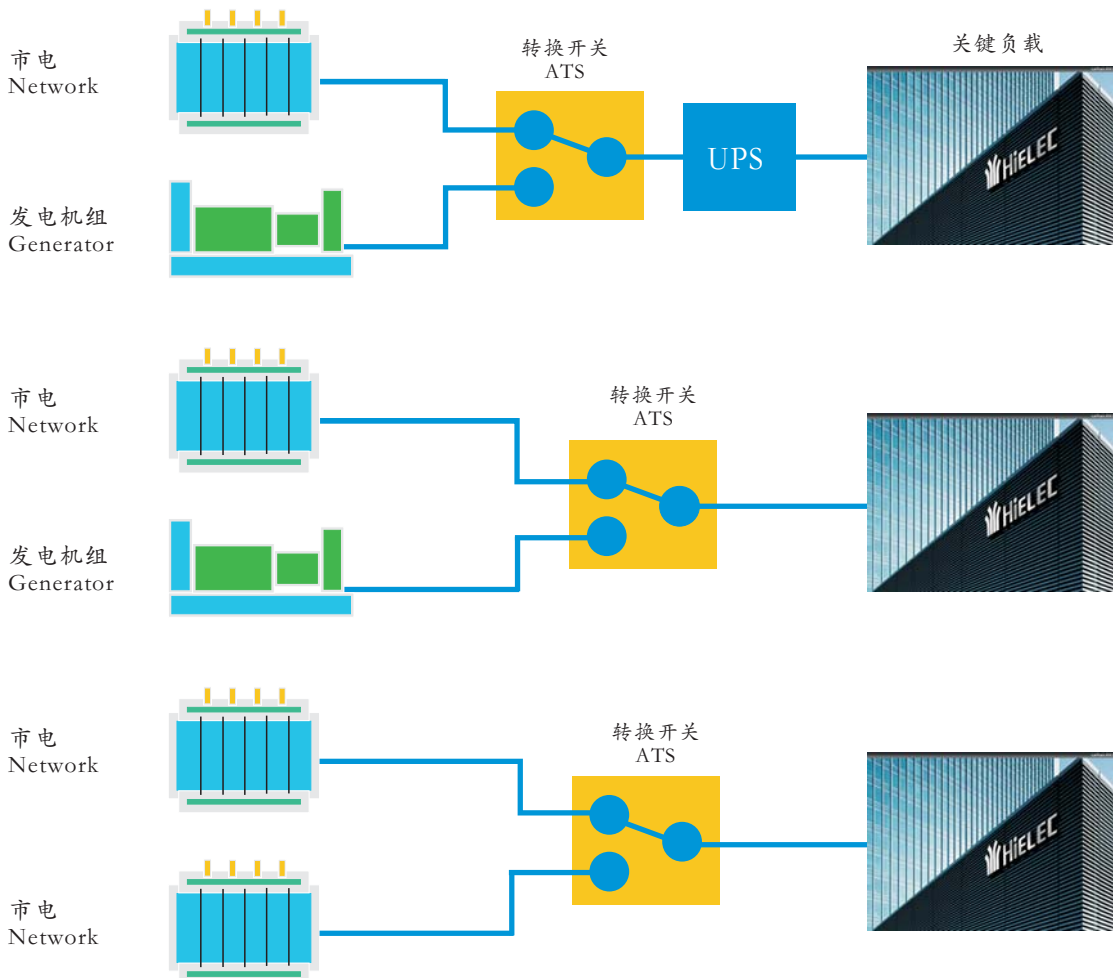

转换开关的其它应用
Other Applications of Transfer Switch

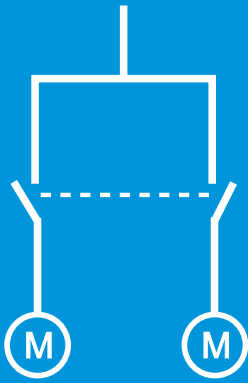

负载转换
Load Transfer

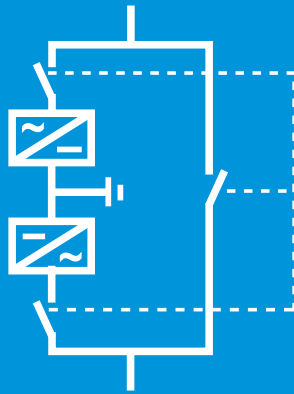

旁路转换
Bypass Transfer

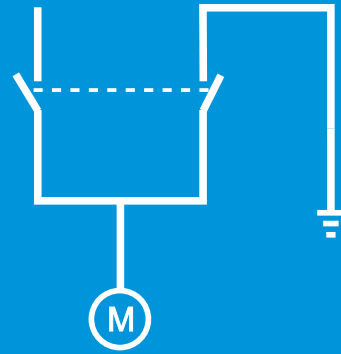

接地转换
Earthing Transfer

负载类型
Load Duty Category

电流性质 Current Type	使用类别 Operation		典型用途 Load Type
	频繁操作 Frequent	不频繁操作 Infrequent	
交流 AC	AC-31A	AC-31B	阻性或微感负载 Resistive loads including moderate overloads
	AC-33A	AC-33B	电动机负载或其他高感性负载 Loads made of motors or other highly inductive loads
	AC-35A	AC-35B	放电灯负载 Dis-charge lamp
	AC-36A	AC-36B	白炽灯负载 Incandescent lamp
直流 DC	DC-31A	DC-31B	阻性或微感负载 Resistive loads including moderate overloads
	DC-33A	DC-33B	电动机负载或包含电动机的混合负载 Loads made of motors or other highly inductive loads
	DC-36A	DC-36B	白炽灯负载 Incandescent lamp



上海海亿电气有限公司

SHANGHAI HIELEC ELECTRICAL

传真(Fax): 021-64607802

电话(Tel): 021-64607801

E-mail: haiyi@hielec.com

商务地址: 上海市闵行区珠城路118弄12号1402

工厂地址: 上海市嘉定区嘉新公路835弄25号

授权经销商
DISTRIBUTOR